

SAFETY BULLETIN

No:6

**Interplane
spol.s r.o.**

Type of airplane: Skyboy- all models

For serial numbers: all serial numbers

Require arrangement: ***Lock control stick front console bolts.***

Perform to: 15 June 2006

Parts add: Interplane s.r.o.
Zbraslavice
Czech republik

Provide: owner of airplane

Appendix: 1 sheet (figures)

Prodedure:

- 1) Remove seats
- 2) Unscrew two safety belts bolts on the sides of central tunel. Fig1, No1
- 3) Remove center tunel Fig 1, No 2
- 4) Find console Fig 2, No 13 in Fig1 Area 3
- 5) Unsrew one bolt on front console Fig 2, No 130 Step 1in Fig3
- 6) Drill asmall hole in the head of the bolt. Fig 3, Step 2
- 7) Screw the bolt beck in. Use Loctite. Fig 3, Step 3
- 8) Repete the same procedure on second bolt. Fig 3, Steps 4-6
- 9) Wire the bolts together. Fig 3, Step 7
- 10) Check to make sure bolts are tight
- 11) Reinstall center tunnel
- 12) Reattach safety belts bolts

Notice: Replacement parts do not change a weight or C. G. possition.
Weight and balance procedure is not necessary.

Interplane s.r.o.

Zbraslavice, 14.June 2006

.....
C.E.O.
Marek Ivanov

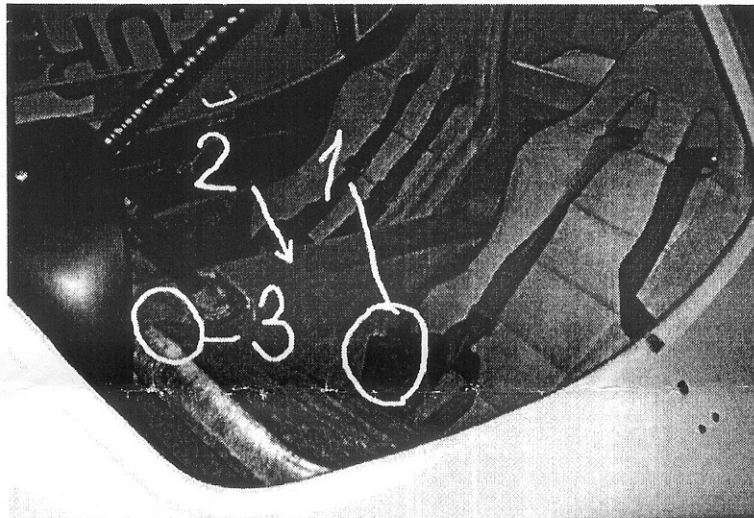

Figure 1

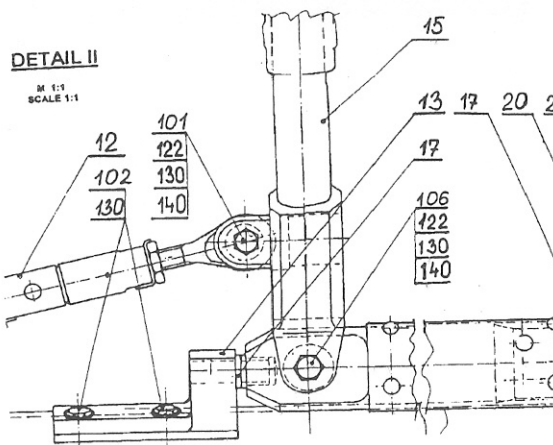

Figure 2

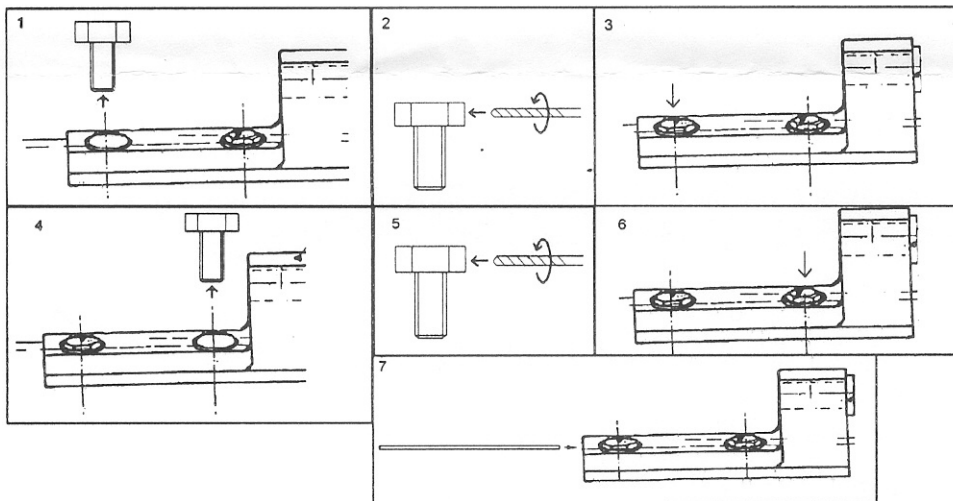

Figure 3